

# Model EDRE: High Capacity Water Heater

## Domestic Hot Water Charging System

50 - 2,000 kW for steam / water operation

**“The Green Calorifiers”**



### Description

- Pressure-resistant storage tank and external shell & tube heat exchanger made of high quality corrosion resistant stainless steel 1.4571/Duplex. The systems comply with the SVGW guidelines for reducing a Legionella infection risk at large-scale systems.
- Optimum hygiene through short storage time of the hot water, low standby losses and small space requirements of the compact system due to high performance of the heat exchanger and small storage capacity.
- Fibre-fleece insulation of storage tank with robust outer sheathing made of PP (RAL7037), patented aluminum closure strips and self-fixing closure caps, quick and easy installation, 80mm insulation up to 1,000 liters and 100mm above. 100% recyclable, fire protection class B2 (B1 upon request)
- Highly efficient heat transfer and most extensive prevention of liming and scaling through self-cleaning effect of patented shell & tube heat exchangers with free floating turbulator rods made of stainless steel.
- Constant hot water temperature during charging and thus the highest comfort at the hot water supply by primary flow adjusting by condensate control valve. Steam-side barrier prevents overheating of the hot water in the heat exchanger. The heat exchanger block is pre-assembled and pre-wired at the factory with strainer, condensate drain, non-return valve, safety valve and shut off valve.
- Safe plant operation without danger of creeping performance decrease due microprocessor controlled storage regulation with differential pressure monitoring of the shell & tube heat exchanger.
- Microprocessor control with touch screen for clear and easy use. Possible remote monitoring and remote control of the system through Ethernet interface. Logging and monitoring of the performance of the system and the individual components.
- Production by TÜV certified welding company according to HP-0 and ISO 3834-2, approval to SVGW and certified according to ISO 9001: 2015.
- Simple installation and short mounting time due to pre-assembled units.
- Maximum pressure: secondary 6, or 10bar; primary 6 or 10bar; higher ratings possible on request

### Optional: Additional Storage

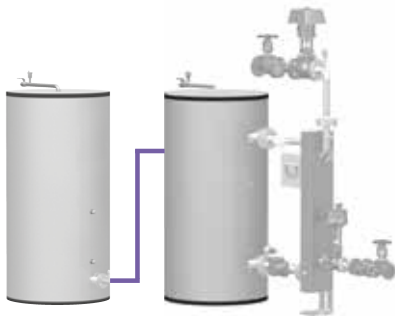

If more storage capacity is required and/or the height of the boiler room is too low, the EDRE heat exchanger can also be operated with two storage tanks or more.

**Limescale Protection via external cold water flush**

**Read more on page 30**

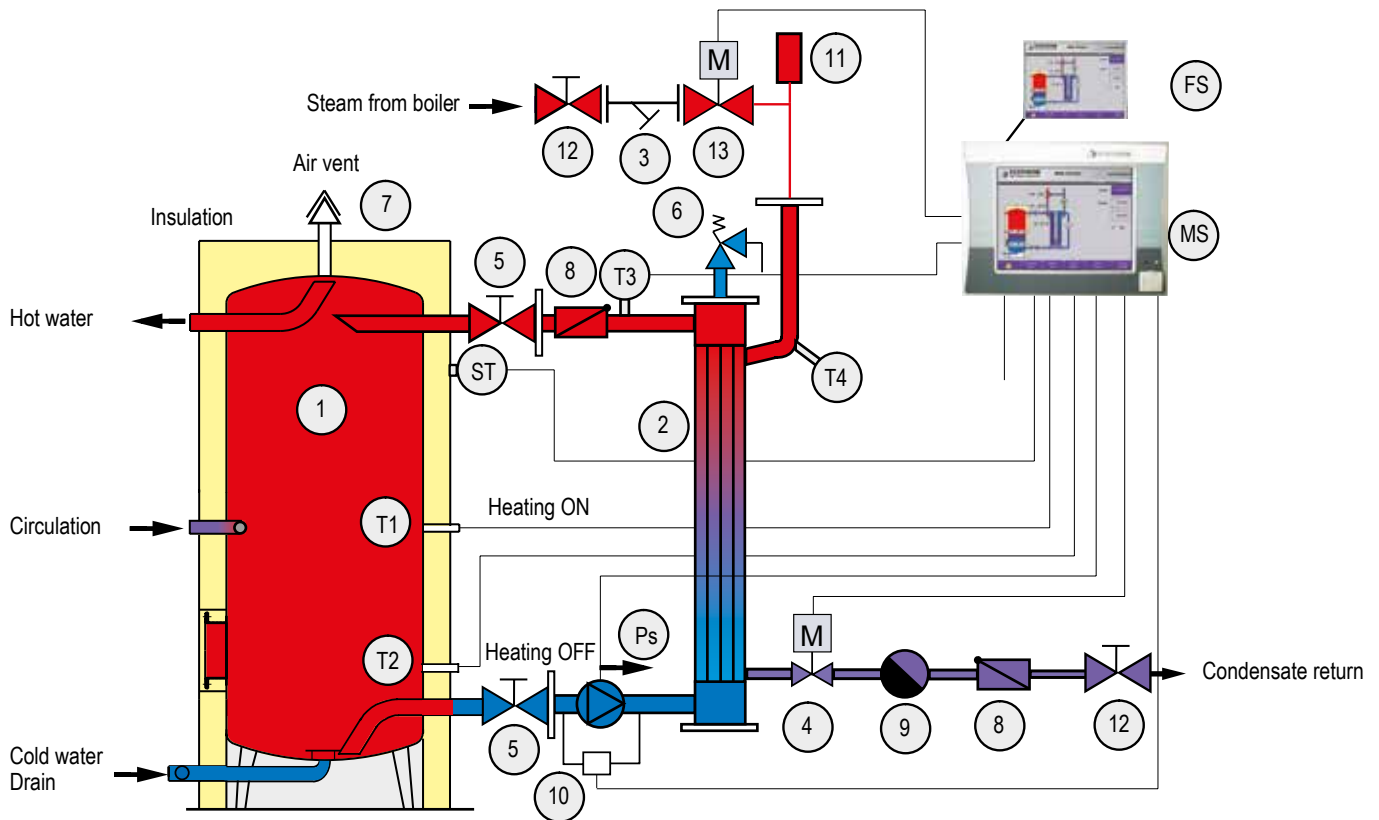

**EDRE High Capacity Water Heater**

- 1** **Stainless steel hot water storage tank**, standing, with removeable fibre-fleece insulation shell
- 2** **Stainless steel heat exchanger** with patented free floating turbulating rods, pre-assembled with piping
- 3** **Strainer** to protect control components
- 4** **2 way condensate control valve with electric actuator** controlled by T3 to regulate the hot water temperature
- 5** **Manual gate valve** for inspection or removal of heat exchanger without draining the tank or losing service
- 6** **Safety pressure valve** set at 10 or 6 bar, corresponding to maximum tank operating pressure
- 7** **Automatic air vent** and anti-vacuum valve, with manual cock for rapid air expulsion during tank filling
- 8** **Non-return valve** for prevention of hot water/ condensate convection back flow during standby
- 9** **Steam trap** ensures protection of control components from steam
- 10** **Differential pressure sensor** for monitoring heat exchanger fouling
- 11** **Vacuum breaker**
- 12** **Shut off valve:** Shut off from steam and condensate system
- 13** **Two way high temperature safety and shut off valve** with electric actuator
- T1** **Temperature sensor "heating on":** Signal to start preheating and charging
- T2** **Temperature sensor "heating off":** Signal that heating is complete. Activation of anti-fouling cycle.
- T3** **Temperature sensor to regulate the temperature of hot water entering the tank** by controlling the 2 way condensate control valve (item 4). Used also to monitor the anti-fouling cycle.
- T4** **Temperature sensor monitoring the incoming steam temperature** to ensure that sufficient heat is available to produce hot water at the required temperature. Also for monitoring the anti-fouling cycle.
- P<sub>s</sub>** **Secondary circuit pump** circulates cold domestic water from the bottom the the tank into the heat exchanger
- ST** **Safety thermostat** shuts down system if manually set temperature is exceeded
- MS** **Microprocessor control unit**
- FS** **Remote control software** for control and monitoring using a PC or BMS via TCP/IP network, or internet.

# Model EDRE: High Capacity Water Heater

## Instantaneous Water Heater

50 - 2,000 kW for steam / water operation



### Description

- Optimum hygiene through short storage time of the hot water, low standby losses and small space requirements of the compact system due to high performance of the heat exchanger and small storage capacity.
- Highly efficient heat transfer and most extensive prevention of liming and scaling through self-cleaning effect of patented shell & tube heat exchangers with free floating turbulator rods made of stainless steel.
- Constant hot water temperature and highest comfort at the hot water supply by primary flow adjusting by condensate control valve. Steam-side barrier prevents overheating of the hot water in the heat exchanger. The heat exchanger block is pre-assembled and pre-wired at the factory with strainer, condensate drain, non-return valve, safety valve and shut off valve.
- Safe plant operation without danger of creeping performance decrease due microprocessor controlled storage regulation with differential pressure monitoring of the shell & tube heat exchanger.
- Microprocessor control with touch screen for clear and easy use. Possible remote monitoring and remote control of the system through Ethernet interface. Logging and monitoring of the performance of the system and the individual components.
- Production by TÜV certified welding company according to HP-0 and ISO 3834-2, approval to SVGW and certified according to ISO 9001: 2015.
- Simple installation and short mounting time due to pre-assembled units.
- Maximum pressure: secondary 6, or 10bar; primary 6 or 10bar; higher ratings possible on request

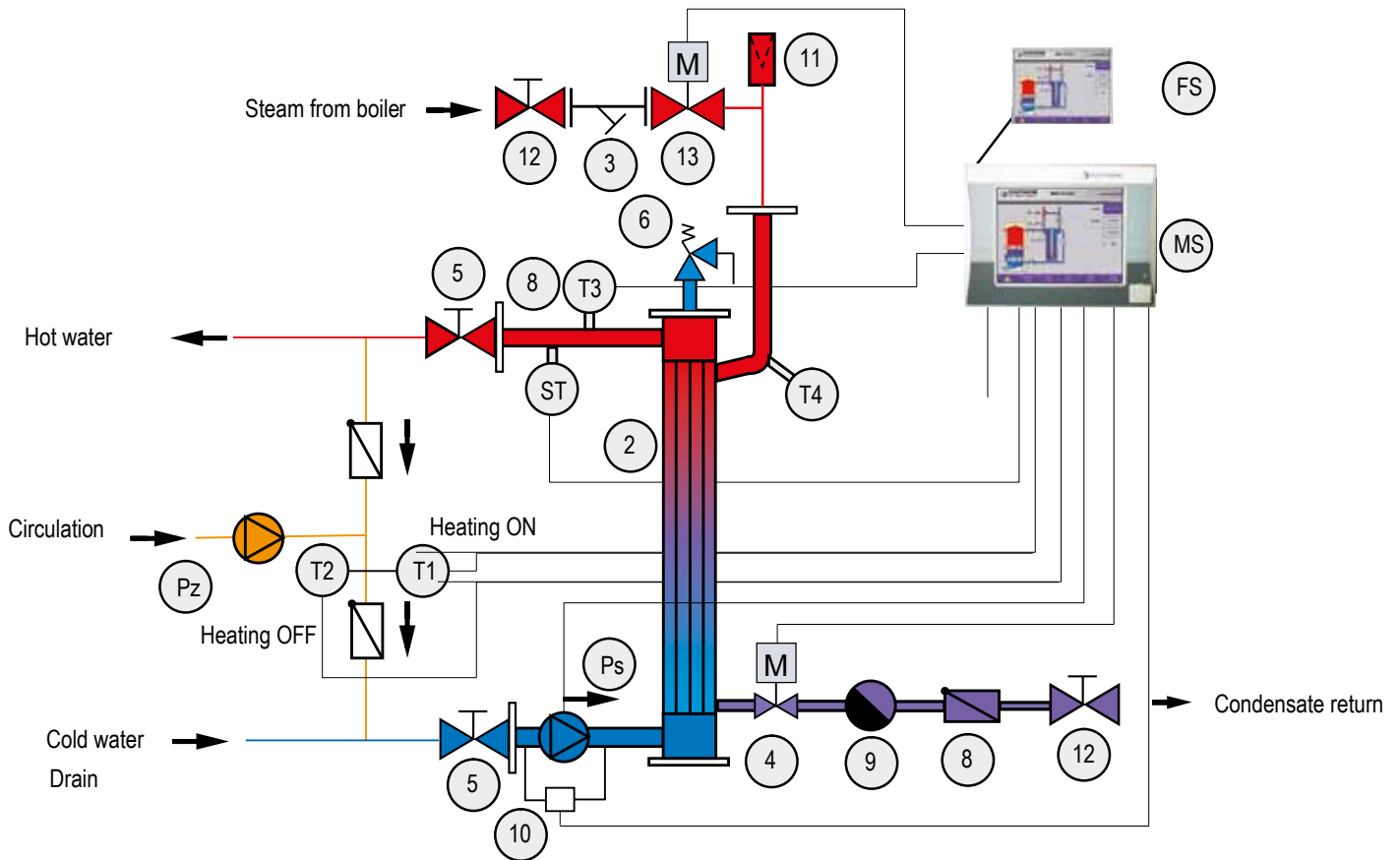

- 2 Stainless steel heat exchanger** with patented free floating turbulating rods, pre-assembled with piping
- 3 Strainer** to protect control components
- 4 2 way condensate control valve with electric actuator** controlled by T3 to regulate the hot water temperature
- 5 Manual gate valve** for inspection or removal of heat exchanger without draining the tank or losing service
- 6 Safety pressure valve** set at 10 or 6 bar, corresponding to maximum tank operating pressure
- 7 Automatic air vent** and anti-vacuum valve, with manual cock for rapid air expulsion during tank filling
- 8 Non-return valve** for prevention of hot water/ condensate convection back flow during standby
- 9 Steam trap** ensures protection of control components from steam
- 10 Differential pressure sensor** for monitoring heat exchanger fouling
- 11 Vacuum breaker**
- 12 Shut off valve:** Shut off from steam and condensate system
- 13 Two way high temperature safety and shut off valve** with electric actuator

- T1 Temperature sensor "heating on":** Signal to start preheating and charging
- T2 Temperature sensor "heating off":** Signal that heating is complete. Activation of anti-fouling cycle.
- T3 Temperature sensor to regulate the temperature of hot water entering the tank** by controlling the 2 way condensate control valve (item 4). Used also to monitor the anti-fouling cycle.
- T4 Temperature sensor monitoring the incoming steam temperature** to ensure that sufficient heat is available to produce hot water at the required temperature. Also for monitoring the anti-fouling cycle.
- P<sub>s</sub> Secondary circuit pump** circulates cold domestic water from the bottom the the tank into the heat exchanger
- ST Safety thermostat** shuts down system if manually set temperature is exceeded
- MS Microprocessor control unit**
- FS Remote control software** for control and monitoring using a PC or BMS via TCP/IP network, or internet.

# Model EDRE: Performance data

## Performance data model EDRE (steam / water)

for secondary temperatures of 20/60°C

for primary temperatures of 155/95°C (over pressure 4.5bar(g), condensate pressure 0.5bar)

Model	Nominal rating *)	Primary flow [kg/h]	Continuous hot water output [l/h]
Model	kW	155°C (4,5 bar) - 95°C	20°C - 60°C
EDRE	100	172	2.150
EDRE	200	344	4.299
EDRE	300	516	6.499
EDRE	400	688	8.598
EDRE	500	860	10.748
EDRE	600	1.032	12.898
EDRE	700	1.204	15.047
EDRE	800	1.376	17.197
EDRE	900	1.548	19.347
EDRE	1000	1.720	21.496
EDRE	1250	2.150	26.870
EDRE	1500	2.580	32.244
EDRE	1750	3.010	37.618
EDRE	2000	3.440	42.992

\*) higher steam pressure or other nominal ratings available on request

Performance parameters: saturated steam 4,5 bar(g)/155°C, cold water 20°C,

hot water 60°C in tank, 45°C after the mixing unit

The boiler performance rating (kilowatt) must at least match the required performance rating of the overall system to ensure correct operation.

### Conversion factor for Imp. gallon:

1 liter = 0.22 gallons

1 gallon = 4.546 liters

### EDRE: key to model number

Type	kW	t <sub>1</sub>	t <sub>2</sub>	Vol	Opt
1 2 3 4	5	6 7	8 9	10	11

#### Type

1st digit: **E** = ECOTHERM high capacity water heater

2nd digit: **D** = steam boiler

3rd digit: **R** = shell and tube heat exchanger

4th digit: **E/M** = electronic control / mechanical control

#### kW

5th digit: heat exchanger nominal rating in kilowatt

#### t<sub>1</sub>

6th digit: feed temperature from boiler in °C

7th digit: return temperature to boiler in °C

#### t<sub>2</sub>

8th digit: domestic cold water inlet temperature in °C

9th digit: domestic hot water output temperature in °C

#### Vol

10th digit: tank capacity in liters

#### Opt - Options

11th digit: **D** = double tank, **N** = network remote control,

**M** = modem remote control, **A** = electric anode,

**E** = external anti-fouling cooling, **S** = heat exchanger sludge flushing kit

# Floor space requirements EHRE & EDRE

The required floor space of mechanical and electrical equipment plays an important role when it comes to determining the overall building costs. Conventional storage type water heaters require a large amount of space. ECOTHERM EHRE & EDRE high capacity water heaters require up to 95 % less floor space. These savings can lead to a significant reduction of the total costs of the establishment of a new building.

## space requirement for main tank

storage capacity	B*	D1	D2	F min.	S min.	T	P min.	tank weight (empty)
liters	mm	mm	mm	mm	mm	mm	mm	kg
300	500	500	660	1000	600	1460	1860 x 1060	50
540	500	650	810	1000	600	1610	2010 x 1210	65
750	500	750	910	1000	600	1710	2110 x 1310	85
1000	500	890	1050	1200	600	1910	2250 x 1450	115
1250	500	950	1150	1200	600	1950	2350 x 1550	150
1500	500	1100	1300	1200	600	2100	2500 x 1700	200
2000	500	1250	1450	1400	600	2250	2650 x 1850	235
2500	500	1350	1550	1400	600	2350	2750 x 1950	300
3000	500	1350	1550	1400	600	2350	2750 x 1950	335
4000	500	1500	1700	1600	600	2500	2900 x 2100	460
5000	500	1650	1850	1600	600	2650	3050 x 2250	500

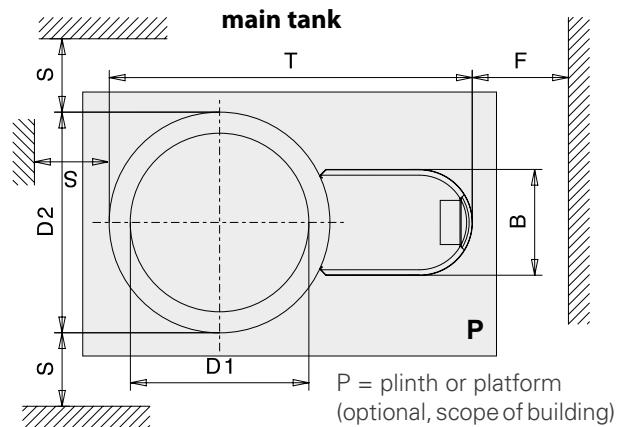

\*) heat exchanger > 300 kW B\* = 710 mm

## space requirement for each additional tank

storage capacity	D1	D2	S Minimum	additional plinth P <sub>2</sub> Minimum
liters	mm	mm	mm	mm
300	500	660	600	1530 x 1060
540	650	810	600	1710 x 1210
750	750	910	600	1810 x 1310
1000	890	1050	600	1950 x 1450
1250	950	1150	600	2050 x 1550
1500	1100	1300	600	2220 x 1700
2000	1250	1470	600	2350 x 1850
2500	1350	1550	600	2450 x 1950
3000	1350	1570	600	2470 x 1970
4000	1500	1700	600	2600 x 2100
5000	1650	1850	600	2750 x 2250

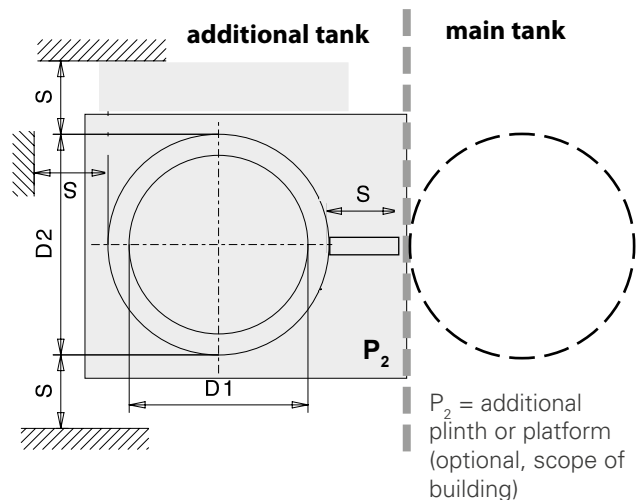

## Port dimensions and heights

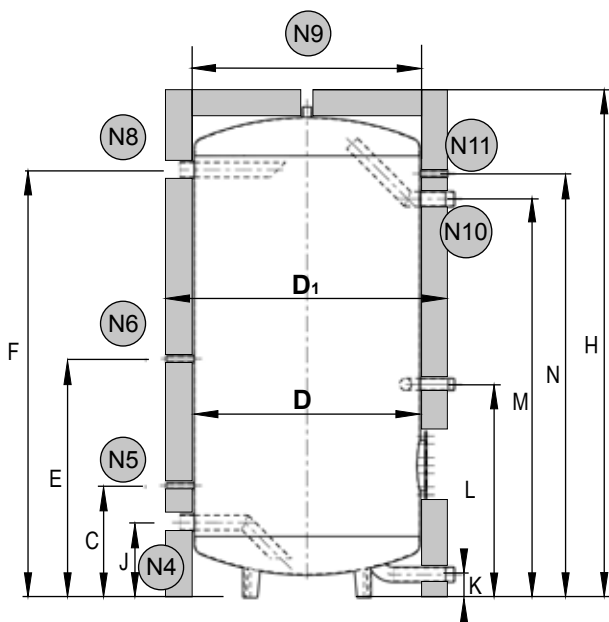

### pipng port sizes

port Nr.	port size	function description
N1/N2	2" AG	cold water port / drain
N3 smaller than 3.000 l	Di 200	purification flange
N3 bigger than 3.000 l	Di 400	manhole
N4	2" IG	outlet to external heat exchanger
N5/N6	1/2" IG	temperature sensors (N6=T1/ein, N5=T2/aus)
N7	6/4" AG	circulation port
N8	2" IG	inlet from external heat exchanger
N9	1" IG	air vent
N10	2" AG	hot water port

### pipng connection heights, overall height

Storage Capacity	D	D1	H	F	J	C	E	K	L	M	N	Weight
<b>Liter</b>	mm	mm	mm	mm	mm	mm	mm	mm	mm	mm	mm	mm
<b>300</b>	500	700	1922	1685	295	440	940	90	840	1570	1580	71
<b>540</b>	650	850	1942	1685	295	440	940	90	840	1570	1580	85
<b>750</b>	750	950	1952	1685	295	440	940	90	840	1570	1660	113
<b>1000</b>	890	1090	1963	1685	295	440	940	90	840	1570	1660	147
<b>1250</b>	950	1190	1969	1685	295	440	940	90	840	1570	1660	197
<b>1500</b>	1100	1340	2003	1705	315	460	960	90	860	1590	1660	228
<b>2000</b>	1250	1490	2040	1705	315	460	960	90	860	1590	1660	335
<b>2500</b>	1350	1590	2100	1705	315	460	960	90	860	2090	1660	417
<b>3000</b>	1350	1590	2615	1705	315	460	960	90	1060	2190	2160	470
<b>4000</b>	1500	1740	2630	1805	415	560	1060	90	1160	2190	2210	557
<b>5000</b>	1650	1890	2900	1805	415	560	1060	90	1160	2190	2210	662
<b>6000</b>	1650	1890	3000	1840	450	600	1100	90	1300	2500	2230	740
<b>7000</b>	1900	2140	3500	1840	450	675	1175	90	1430	2821	2230	825
<b>8000</b>	1900	2140	4100	1920	530	675	1175	120	1580	3121	2230	910